



VARISCITE LTD

i.MX8 Camera Board - 13 MP autofocus, color, MIPI 4-lane

Variscite PN: VCAM-AR1335E

Camera Board: e-CAM130_iMX8

Camera Sensor: AR1335 CMOS image sensor



VARISCITE LTD.

VCAM-AR1335E Datasheet

© 2019 Variscite Ltd.

All Rights Reserved. No part of this document may be photocopied, reproduced, stored in a retrieval system, or transmitted, in any form or by any means whether, electronic, mechanical, or otherwise without the prior written permission of Variscite Ltd.

No warranty of accuracy is given concerning the contents of the information contained in this publication. To the extent permitted by law no liability (including liability to any person by reason of negligence) will be accepted by Variscite Ltd., its subsidiaries or employees for any direct or indirect loss or damage caused by omissions from or inaccuracies in this document.

Variscite Ltd. reserves the right to change details in this publication without notice. Product and company names herein may be the trademarks of their respective owners.

Variscite Ltd.
4, Hamelacha Street
Lod
P.O.B 1121
Airport City, 70100
ISRAEL

Tel: +972 (9) 9562910
Fax: +972 (9) 9589477

1 Lens Datasheet



e-con Systems India Pvt Ltd

7th Floor, RR Tower - IV,
Super A-16 & A-17, Thiru-Vi-Ka Industrial Estate,
Guindy, Chennai - 600 032.

www.e-consystems.com

e-CAM130_IMX8M



Lens Datasheet

Revision 1.1

13 May 2019



www.e-consystems.com | Subject to change without notice

Page 1 of 6

2 Introduction

e-CAM130_iMX8M is a 13 MP autofocus, color, MIPI 4-lane camera daughter board which has been designed and developed by e-con Systems, a leading Embedded Product Design Services Company which specializes in the advanced camera solutions. e-CAM130_iMX8M is a two-board solution which includes ACC-iMX8M-ADP and e-CAM136_MI1335_ADG board. This camera daughter board can be directly interfaced to the DART-MX8M carrier board (VAR-DT8MCustomBoard).

The camera adaptor board is based on AR1335 CMOS image sensor from ON Semiconductor®. AR1335 is a 1/3.2" optical form-factor, CMOS image sensor with an electronic rolling shutter.

This document describes the optical specifications of lens used in e-CAM130_iMX8M.

3 Disclaimer

e-con Systems reserves the right to edit or modify this document without any prior intimation or whatsoever.

4 Description

The lens used in e-CAM130_iMX8M is a high resolution, and 1/3.2" format lens. It provides a maximum Field of View (FOV) of 74.4 degrees with 1/3.2" format AR1335 CMOS image sensor.

5 Optical Specifications

The optical specifications of lens are listed in the following table.

Description	Specification
Imager Format	1/3.2"
Focal Length	3.81 mm
Aperture (F/#)	2.2
FOV	74.4°(D), 60.2°(H), 46.4°(V)
Distortion	Less than 1.5%
Chief Ray Angle	N/A

Table 1: Optical Specifications of Lens

6 Mechanical Dimensions

The mechanical dimensions of lens used in e-CAM130_iMX8M is shown in the following figure.



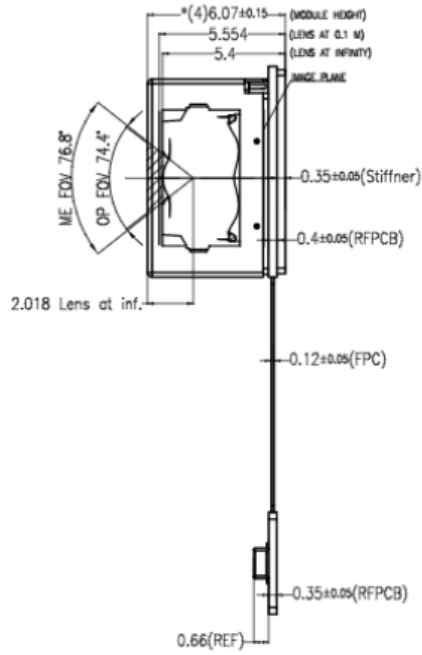

Figure 1: Lens Mechanical Dimensions



2 Camera Datasheet



e-con Systems India Pvt Ltd

7th Floor, RR Tower - IV,
Super A-16 & A-17, Thiru-Vi-Ka Industrial Estate,
Guindy, Chennai - 600 032.
www.e-consystems.com

e-CAM130_iMX8M



Datasheet

Revision 1.2
14th May 2019



www.e-consystems.com | Subject to change without notice

Page 1 of 10

2 Introduction

The e-CAM130_iMX8M board is a 13 MP autofocus, color, MIPI 4-lane camera daughter board which has been designed and developed by e-con Systems, a leading Embedded Product Design Services Company which specializes in the advanced camera solutions. E-CAM130_iMX8M is a two-board solution consists of ACC-iMX8M-ADP and e-CAM136_MI1335_ADP board. This camera daughter board can be directly interfaced to the Variscite's DART-MX8M carrier board (VAR-DT8McustomBoard).

The camera adaptor board is based on AR1335 CMOS image sensor from ON Semiconductor®. The AR1335 is a 1/3.2" optical form-factor, CMOS image sensor with an electronic rolling shutter.

e-CAM130_iMX8M can stream uncompressed VGA at 120 fps, HD at 80 fps, FHD at 60 fps, 4K at 15 fps (QFHD) YUYV formats. This can also stream the uncompressed 13 MP at 10 fps.

This document describes the features of e-CAM130_iMX8M board and the pin-outs of the connectors including with mechanical diagram.

3 Disclaimer

The specifications and features of e-CAM130_iMX8M camera board are provided here as reference only and e-con system reserves the right to edit/modify this document without any prior intimation of whatsoever.

4 Description

e-CAM130_iMX8M is a two-board solution consisting of e-CAM136_MI1335_ADP (13 MP autofocus camera adaptor board) and ACC-iMX8M-ADP board. The camera is based on AR1335 image sensor from ON Semiconductor® and an on-board image signal processor. E-CAM130_iMX8M has a 60-pin MIPI CSI interface connector (CN2) that contains signals to interface with DART-MX8M carrier board. The 30-pin micro-coaxial cable is used to connect the ACC-iMX8M-ADP board and the e-CAM136_MI1335_ADP board.

The following figure shows the front view of the e-CAM130_iMX8M board.

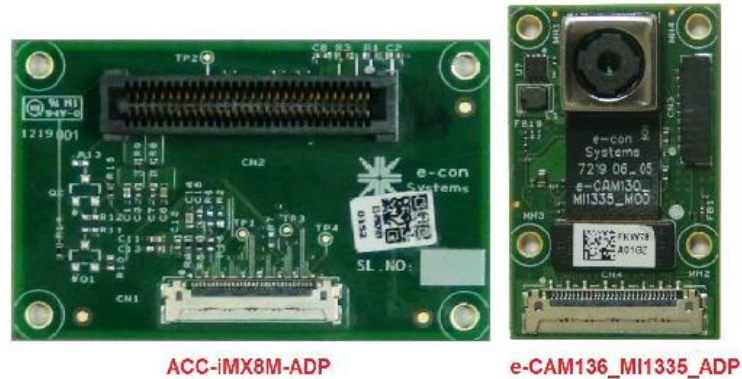

Figure 1: e-CAM130_iMX8M Board

4.1 Features

The features of e-CAM130_iMX8M are as follows:

- Two-board solution.



- 13 MP autofocus camera.
- Light weight, versatile, and portable design.
- Imaging applications.
- 13 MP CMOS image sensor.
- Still capture and preview resolutions: 640 x 480, HD (720p), FHD (1080p), 4K and 13 MP.
- Field of View (FOV) angle is not the same for all preview resolutions.
- Output video format – YUYV format.
- Restriction of Hazardous Substances (RoHS) compliant.

4.2 Key Specifications

The following table lists the key specifications of e-CAM130_IMX8M.

Description	Specification
Base board size (L x W)	ACC-IMX8M-ADP
	e-CAM136_MI1335_ADP
Video format	YUYV
Image resolution	4192 x 3120 (13 MP)
Supported OS	Linux

Table 1: Key Specifications of e-CAM130_IMX8M

5 Pin Description

e-CAM130_IMX8M board consists of micro-coaxial cable connectors (CN1 and CN4) in ACC-IMX8M-ADP and e-CAM136_MI1335_ADP respectively. These two connectors are connected with given micro-coaxial cable. The pin description of connector is explained in the following section.

5.1 Connectors Pin-out Details (CN1 or CN4)

The following table lists the pin-out details of CN1 or CN4 connector.

Pin No	Signal Name	Pin Type*	Description
1	VCC_3P3	POWER	3.3V Power supply
2	VCC_3P3	POWER	3.3V Power supply
3	VCC_1P8	POWER	1.8V Power supply
4	GND	POWER	Ground signal
5	GND	POWER	Ground signal
6	PWDN	OUTPUT	Power down signal
7	I2C_SCL	OUTPUT	I2C Clock signal
8	I2C_SDA	I/O	I2C Data Signal
9	GND	POWER	Ground signal
10	MIPI_D2_N	INPUT	MIPI Data Lane 2 Differential Pair -
11	MIPI_D2_P	INPUT	MIPI Data Lane 2 Differential Pair +
12	TRIGGER	OUTPUT	Camera Trigger signal
13	RSVD	-	Reserved



14	GND	POWER	Ground signal
15	MIPI_D1_N	INPUT	MIPI Data Lane 1 Differential Pair -
16	MIPI_D1_P	INPUT	MIPI Data Lane 1 Differential Pair +
17	GND	POWER	Ground signal
18	GND	POWER	Ground signal
19	MIPI_D0_N	INPUT	MIPI Data Lane 0 Differential Pair -
20	MIPI_D0_P	INPUT	MIPI Data Lane 0 Differential Pair +
21	RESET	OUTPUT	Camera reset signal(Active low)
22	GND	POWER	Ground signal
23	RSVD	-	Reserved
24	MIPI_CLK_N	INPUT	MIPI Clock Lane Differential Pair -
25	MIPI_CLK_P	INPUT	MIPI Clock Lane Differential Pair +
26	GND	POWER	Ground signal
27	MIPI_D3_N	INPUT	MIPI Data Lane 3 Differential Pair -
28	MIPI_D3_P	INPUT	MIPI Data Lane 3 Differential Pair +
29	FLASH	INPUT	Camera flash signal
30	RSVD	-	Reserved

Table 2: Pin Mapping Details

*Pin type is specified with respect to the CN1 connector.

5.2 Connector Part Numbers

The following table lists the connectors used in the e-CAM130_IMX8M camera board and its compatible mating connectors.

Connector	Description	Manufacturer	Part Number
MIPI CSI connector (CN2)	60 Position female connector, Dual Edge Gold 0.031" (0.80 mm) Black	Samtec	HSEC8-130-01-SM-DV-A
Micro-coaxial cable connector	0.4 mm pitch fully shielded 30-pin Receptacle connector	I-PEX	20682-030E-02
GPIO header on camera adaptor board	10 Position socket connector 0.031" (0.80 mm) surface mount, Right Angle Tin.	Hirose Electric Co Ltd	DF52-10S-0.8H(21)
Mating connector for GPIO header on camera adaptor board	10 Position Rectangular Housing Connector Plug Black 0.031" (0.80 mm)	Hirose Electric Co Ltd	DF52-10P-0.8C
Wire crimp	Contact Crimp Non-Gendered 28-32 AWG Tin	Hirose Electric Co Ltd	DF52-2832PCF

Table 3: Connector Part Numbers



6 Electrical Specification

The following section lists down the electrical specification and recommended operating conditions of the e-CAM130_IMX8M camera board.

The values described in this section are measured in e-con Systems lab and this can be used as reference only. The current measurements are typical values and are subject to change for different camera boards under different conditions. However, these values can be taken as a reference for power estimation and power supply design.

6.1 Recommended Operating Condition

The following table lists the recommended operating condition of e-CAM130_IMX8M camera board.

Parameter	Typical Voltage (V)	Operating	Typical Power Consumption (mW)
Operating mode power @ 720p 80fps	3.3 and 1.8		896
Standby mode power			134

Table 4: Recommended Voltage

6.2 Power Consumption

The following table lists the current consumed by the e-CAM130_IMX8M under various operating conditions.

S. No	Parameter	Current (mA) from 3.3V	Current (mA) from 1.8V	Power Consumption (mW)
1	640 x 480 at 120 fps	194	47	725
2	1280 x 720 at 80 fps	246	47	896
3	1920 x 1080 at 60 fps	218	49	808
4	3840 x 2160 at 15 fps	232	51	857
5	4192 x 3120 at 10 fps	210	52	787
6	Standby mode	29	21	134

Table 5: Power Consumption in YUYV

6.3 Functional Temperature Range

The following table lists the functional temperature range of e-CAM130_IMX8M.

Temperature Range	Parameter Description
-30°C to 70°C	Electrically functional operating range

Table 6: Functional Temperature Range

Note: As the temperature increases, the noise level also increases.

7 Mechanical Specifications

The mechanical specifications of the ACC-IMX8M-ADP board and e-CAM136_MI1335_ADAP board with its dimensions are described in the following sections.



7.1 ACC-IMX8M-ADP Board Dimension

The front view of the ACC-IMX8M-ADP board with its dimensions are shown in the following figure.

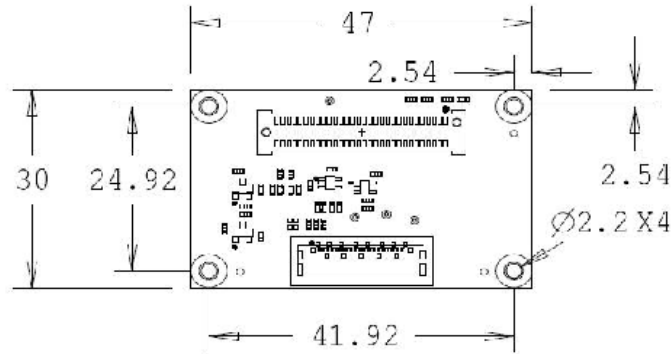

Figure 2: ACC-IMX8M-ADP Board Mechanical Dimensions

7.2 e-CAM136_MI1335_ADP Board Dimension

The top view of the e-CAM136_MI1335_ADP board with its dimensions are shown in the following figure.

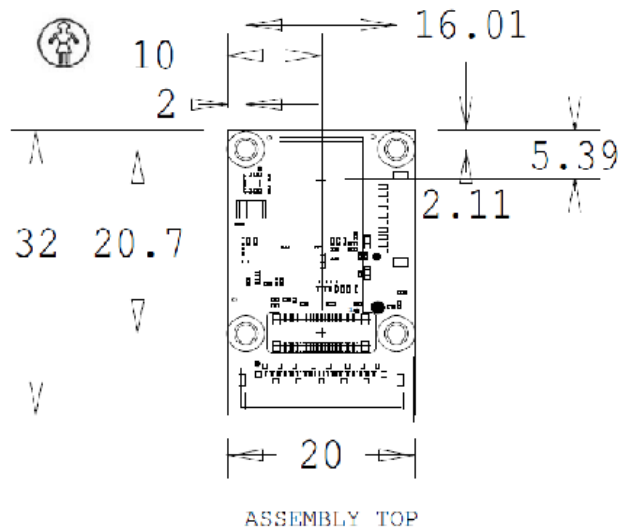

Figure 3: e-CAM136_MI1335_ADP Board Mechanical Dimensions (Top View)



The bottom view of the e-CAM136_MI1335_ADP board with its dimensions are shown in the following figure.

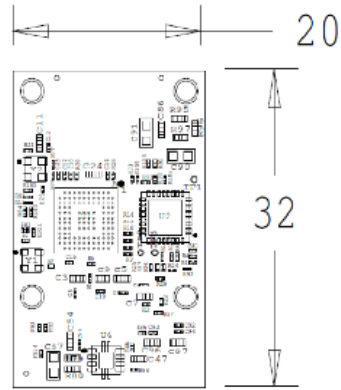

Figure.4: e-CAM136_MI1335_ADP Board Mechanical Dimension (Bottom View)

Note-All dimensions are in mm



Legal notice

Variscite LTD (“Variscite”) products and services are sold subject to Variscite’s terms and conditions of sale, delivery and payment supplied at the time of order acknowledgement.

Variscite warrants performance of its products to the specifications in effect at the date of shipment. Variscite reserves the right to make changes to its products and specifications or to discontinue any product or service without notice. Customers should therefore obtain the latest version of relevant information from Variscite to verify that the information is current.

Testing and other quality control techniques are utilized to the extent Variscite deems necessary to support its warranty.

Specific testing of all parameters of each device is not necessarily performed unless required by law or regulation.

In order to minimize risks associated with customer applications, the customer must use adequate design and operating safeguards to minimize inherent or procedural hazards. Variscite is not liable for applications assistance or customer product design. The customer is solely responsible for its selection and use of Variscite products. Variscite is not liable for such selection or use nor for use of any circuitry other than circuitry entirely embodied in a Variscite product.

Variscite products are not intended for use in life support systems, appliances, nuclear systems or systems where malfunction can reasonably be expected to result in personal injury, death or severe property or environmental damage. Any use of products by the customer for such purposes is at the customer’s own risk.

Variscite does not grant any license (express or implied) under any patent right, copyright, mask work right or other intellectual property right of Variscite covering or relating to any combination, machine, or process in which its products or services might be or are used. Any provision or publication of any third party’s products or services does not constitute Variscite’s approval, license, warranty or endorsement thereof. Any third-party trademarks contained in this document belong to the respective third-party owner.

Reproduction of information from Variscite datasheets is permissible only if reproduction is without alteration and is accompanied by all associated copyright, proprietary and other notices (including this notice) and conditions. Variscite is not liable for any un-authorized alteration of such information or for any reliance placed thereon.

Any representations made, warranties given, and/or liabilities accepted by any person which differ from those contained in this datasheet or in Variscite’s standard terms and conditions of sale, delivery and payment are made, given and/or accepted at that person’s own risk. Variscite is not liable for any such representations, warranties or liabilities or for any reliance placed thereon by any person.

Contact information

Headquarters

Variscite LTD
4, Hamelacha St.
Lod.
P.O.B 1121
Airport City, 70100
ISRAEL
Phone +972 (9) 9562910 • Fax +972 (9) 9589477

Tel: +972 (9) 9562910

Fax: +972 (9) 9589477

Sales: sales@variscite.com

Technical support: support@variscite.com

Website: www.variscite.com

